

HARDWARE AND SOFTWARE PROTECTION OF THE POWER SUPPLY AND CONTROL OF THE SERVICE ROBOTS

Vadim Chernyshev, Valentin Pryanichnikov, Mariia Soloveva, Radomir Tarasov & Aleksandr Telegin

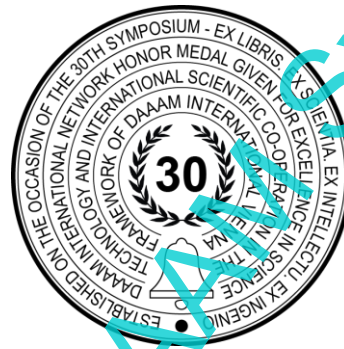

This Publication has to be referred as: Chernyshev, V[adim]; Pryanichnikov, V[alentin]; Soloveva, M[ariia], Tarasov R[adomir] & Telegin, A[lexandr] (2023). Development of a smart battery system with redundant elements for service robots, Proceedings of the 34th DAAAM International Symposium, pp.xxxx-xxxx, B. Katalinic (Ed.), Published by DAAAM International, ISBN 978-3-902734-xx-x, ISSN 1726-9679, Vienna, Austria
DOI: 10.2507/34th.daaam.proceedings.xxx

Abstract

The article is devoted to the development of power supply systems for mobile service robots. An important aspect of the power supply system for autonomous devices is tracking the battery parameters and monitoring the charging and discharging process. For example, an intelligent battery system has been developed for the AMUR-307 robot, which allows you to track all the most important battery parameters and set charging parameters. The system provides a variety of hardware and software protection schemes for current, voltage, temperature, and the state of internal balancing of batteries in assemblies, as well as overload protection of drives. Incorrect actions of operators during supervisory control are analyzed and blocked. The system supports the smart battery specification - SBS v1.1, which provides standardized access to the system from the operating system space. This approach presents significant advantages for the implementation of devices designed for the underwater robotic complex (RC) under development, consisting of a walking base vehicle and autonomous sensor carrier satellites. RC is designed for inspection of underwater objects, delivery and use of cargo in the conditions of the shelf zone and the unprepared bottom with extreme conditions.

Keywords: Mobile service robots; power system; smart battery system; SBS v1.1; Linux power supply.

1. Introduction

This article discusses the design and subsequent integration of the robot's power supply system. To integrate this system, the AMUR-307 service robot is used, designed to transport objects between rooms with the ability to open doors with standard rotary handles [1]. In the process of manufacturing a prototype of the robot, some shortcomings were revealed, one of which was in the power system. In this model, it was planned to install two lithium-ion batteries of the 4S2P topology, each having a battery monitoring module, which are connected in parallel to provide the required current for the operation of the robot kinematics. A significant disadvantage is the inability to track the following important parameters: current, voltage, current charge, and remaining battery capacity, as well as plot the dependencies of all key battery variables. The power supply system developed and installed earlier is shown in Figure 1.

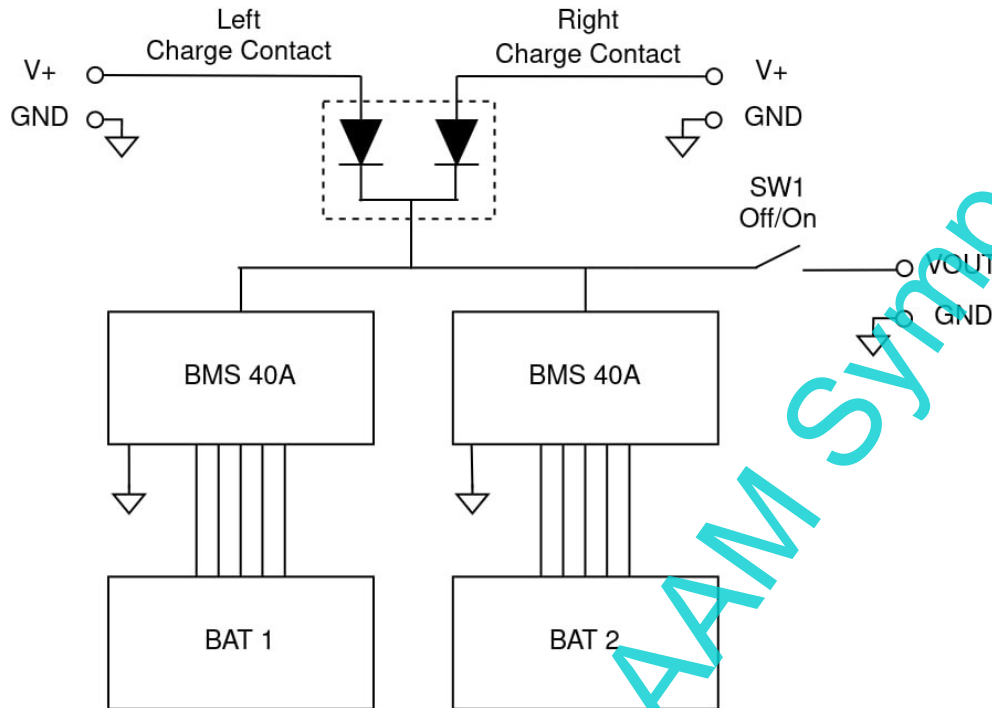

Fig. 1. Structural diagram of the electrical system of the robot

These batteries were supposed to be charged with an external charger, which is connected to the current and voltage regulation module based on a step-down pulse adjustable voltage converter XL4016. As it turned out, this is not a sufficiently optimal and convenient solution. To solve all the identified shortcomings, the task was set to develop an original charging/discharging module and a battery monitoring module with small dimensions. Due to the existing design of the robot, we have limitations in the size of the control electronics and battery charge in 25x30x160 mm.

A direct current source is connected to the terminals to charge lithium-ion batteries. GND serves as the total mass. The SW1 toggle switch is used to ensure that the robot is powered on and off by batteries. VOUT is the power output from the battery pack.

2. Smart battery system

To correct the shortcomings of the mobile robot described earlier, a unified system of intelligent chargers was selected based on the SBS v1.1 specification which includes Smart Battery, Charger, Selector, and System manager. The SBS specification defines the communication between system components via the SMBus interface.

SMBUS is a serial data exchange protocol for power supply devices, which is based on the I2C bus, but at the same time uses a low level of signal voltage (3.3V). This protocol requests information from the battery and then uses it in the power management scheme of the system and/or uses it to provide the user with information about the current state and capabilities of the battery. The SMBus node will also receive critical messages from the Smart Battery when a problem is detected [2]. Smart Battery Charger is one of the elements of a comprehensive system solution for rechargeable batteries used in portable electronic equipment, designed for use with batteries conforming to the Smart Battery Data specification. Smart Battery Charger has charging parameters that are controlled by the battery itself and the host [3]. The combination of Smart Battery and Smart Battery Charger provides clear advantages in terms of security, performance, and cost of the system, namely:

1. Charging characteristics and safety limits are an integral part of the battery itself, ensuring proper charging algorithms that match specific cell types. Each smart battery defines a safe charging scheme that best matches its chemical composition and capacity, maximizing useful energy with each charge, reducing charging time, and increasing the number of charging cycles.
2. The cost of the system is reduced because the charger must provide only the charging voltage and current set by the battery itself, without duplicating the measuring and control electronics already available in the Smart battery.

The block diagram of the nodes and connections of the power supply system in compliance with the SBS specification is shown in Figure 2.

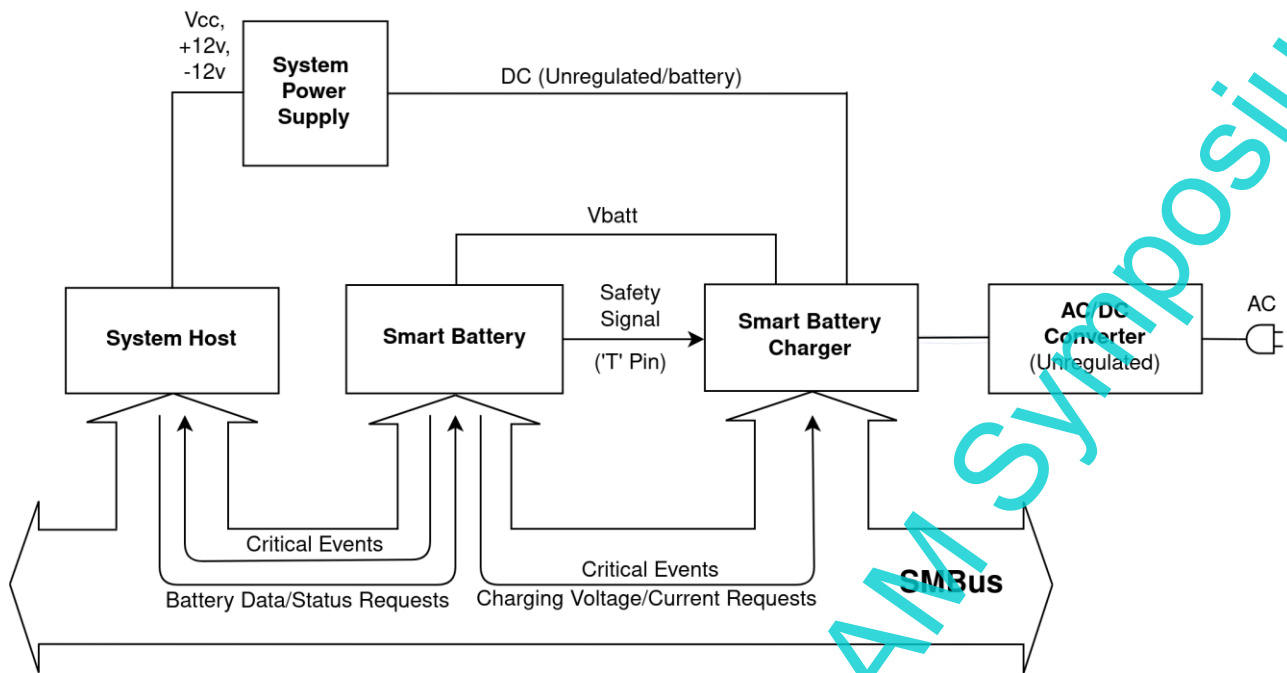

Fig. 2. Block diagram of nodes and connections of the SBS-based system

The choice of this specification has a special advantage over the previous robot power system since it becomes possible to control all processes related to charging and discharging the robot's battery.

Often, for electronic systems using two or more batteries, an active battery selection node is used, but this approach is not suitable for powering the robot, since the battery selection unit appears with this approach involves alternating switching between batteries and the system, and for the robot in question, simultaneous operation with both batteries is assumed to remove large currents.

The considered components of the specification are represented in the Linux OS kernel by power system drivers. To work with charging devices in Linux OS, the Charger Manager utility is used, which provides management of all power devices in the kernel space [4]. This software can provide management and status information on all chargers, batteries and other power devices. Charger Manager can support uevent system notifications, suspension polling in RAM, handling premature battery discharge events, and uevent-notify support. Since there are multiple batteries, multiple instances of Charger Manager use the same structure of power device descriptors, namely `charge_global_desc`, which will manage standby monitoring for all instances of Charger Manager. Charger Manager provides management of power devices inside the core. This software can provide management and status information on all chargers, batteries, and other power devices. Charger Manager can support uevent notifications, suspend polling in RAM, handle premature battery discharge events, and uevent-notify support. Since there are multiple batteries, multiple instances of Charger Manager use the same structure of power device descriptors, namely `charge_global_desc`, which will manage standby monitoring for all instances of Charger Manager. For each independently charged battery, its instance of Charger Manager is launched.

3. BMS module

To meet the SBS specification and the required battery parameters, it was necessary to select a battery management controller. When choosing, such parameters were taken into account as control of battery parameters via the SMBus interface via the Linux kernel, completeness of the protection system, permissible charge and discharge currents, battery balancing current, compactness of the resulting device, and the ability to change the address of the controller since it is necessary to use two battery monitoring boards, independently for each battery.

In the projected battery monitoring system, the necessary monitored protection parameters were determined: the temperature of the battery cells, the temperature of the charge and discharge keys, and the voltage and current of the battery. The sufficient balancing current for the battery is 100 mA. Due to the limitations of the robot's design, the maximum allowable dimensions of each battery control board were 25x80 mm.

After a thorough study of the existing mass-produced battery controllers at the time of development, the BQ40Z50-R2 was chosen as the optimal controller, which is ideally suited for the task of developing a battery control board for the AMUR-307 robot. This controller has many protection mechanisms for the monitored battery parameters: protection against battery discharge below the threshold value, protection against overcharging above the threshold value, protection of the battery from overheating based on four thermistors for each battery assembly, protection against overheating of the charge and discharge keys, protection against overheating of the controller based on the built-in

4. Charger module

After developing the battery control board, it was necessary to develop a robot battery charge board. As a design solution, the development of a cross-board was chosen in which the battery monitoring modules described in the previous section will be installed. After a thorough analysis of the charge controllers, the choice was made on two LTC1760 and BQ24735 chips.

The LTC1760-based solution offers the possibility of independent, but simultaneous charging and discharging of two batteries without the problem of energy flows between the batteries, such a solution would allow installing batteries on the robot regardless of their degree of charge, so in the worst case, when one battery is completely discharged and the other is charged, there would be no overflows that would violate the protection of the boards. However, this controller has a significant drawback, this is the maximum charging current of 4A.

The BQ24735-based solution initially works with only one battery, so there is a problem with large currents between the batteries, but this controller has a maximum charge current of 8A, which is great for charging both batteries at the estimated time. The problem with overflows between batteries can be solved in three ways:

1. Recommendation for installers of robot batteries, which says that robot batteries should differ from each other in charge level by no more than 10%. Then the currents between the batteries will not exceed the permissible charging currents for the batteries and spoil their life.
2. Using two separate charge controllers, with parallel connection of power outputs and charging inputs between them.
3. Duplicate keys for two batteries, but also control the circuit of one controller.

We actively use the first method, but human error is permissible during maintenance, as a result, it is necessary to use another method. The method using separate charge controllers is supported by the Linux kernel, however, the scheme is greatly complicated because all suitable controllers have a non-configurable I2C address, therefore, the cost increases, the method of protection based on duplicate keys allows using one controller, however, the charging process will occur simultaneously on both batteries and is limited only by the battery status controller. Due to the described features of each approach, the optimal solution is to use independent lines BQ40Z50-R2 + BQ24735 + CP2112. The developed block diagram of the power supply system is shown in Figure 5.

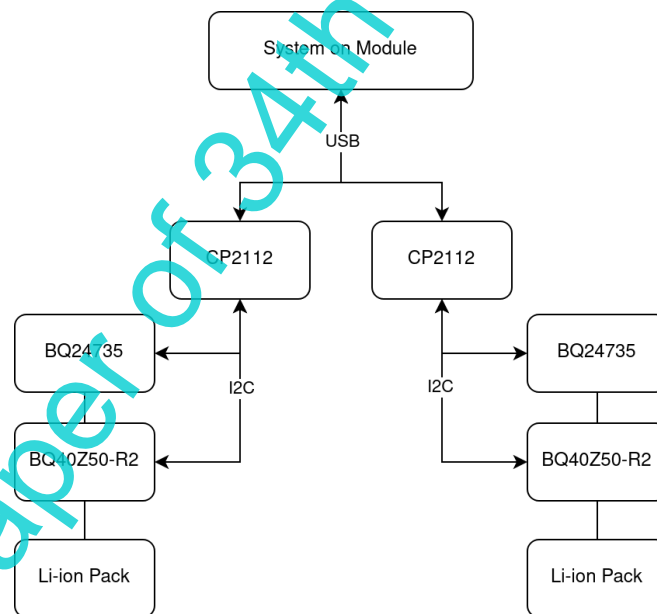

Fig. 5. Block diagram of the battery control board

Also in this version, a broadcast mode can be used, where the BQ40Z50-R2 sends commands and status parameters directly to the BQ24735 charge controller bypassing processor processing, which increases the system's response speed, as well as its security [9].

After forming the structure of the robot's battery monitoring and charging system, as well as selecting components, a schematic electrical diagram and a charge control board for the robot were designed.

The developed power system will also be integrated on the underwater walking vehicle platform with the increase of independent power circuits from two to four [12], [13].

5. Docking station

For the process of charging the robot, a robot charging dock was developed and manufactured, a 20V 8A power supply unit was installed on board the dock station, a mechanism for disconnecting the power supply in the absence of a connected robot, and contact pads for charging the robot. Two groups of spring-loaded contacts are installed on the robot from the right and left sides to ensure confident contact with the docking station even in the event of a robot's arrival with an angle to the normal of the contact plane on the front panel of the docking station up to 15 degrees. The appearance of the AMUR-307 series robot docking station is shown in Figure 6.

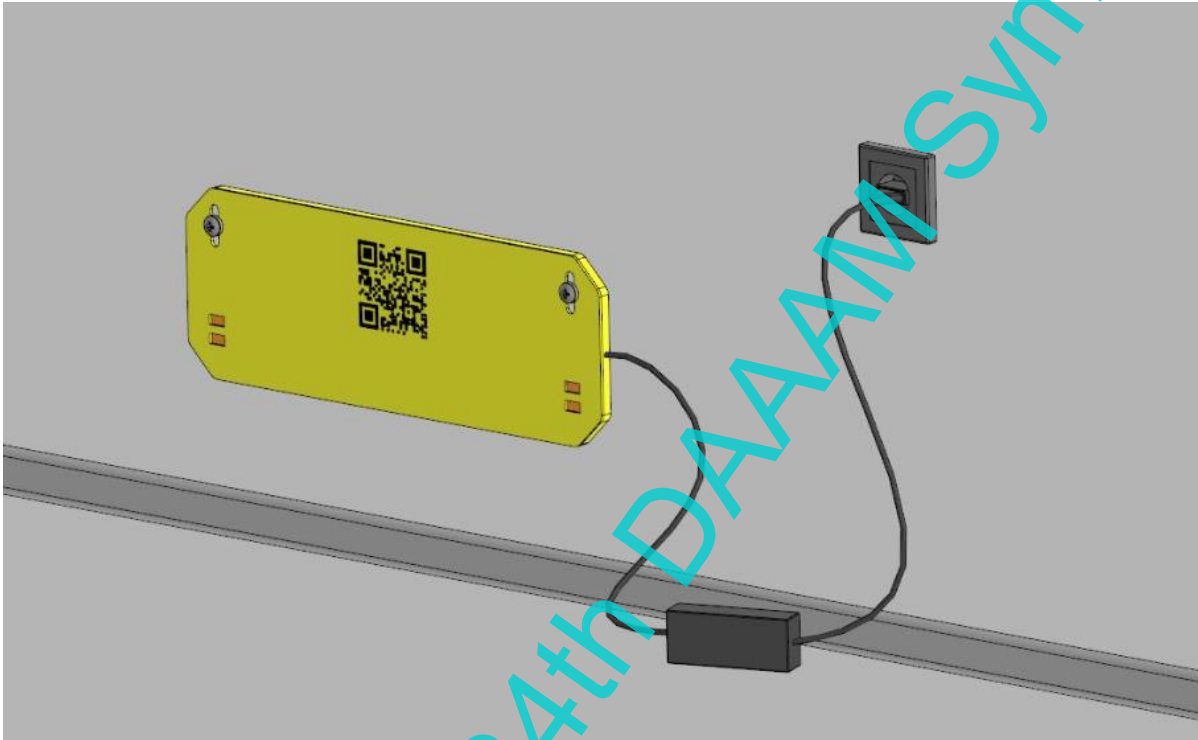

Fig. 6. Appearance of the AMUR-307 series robot docking station

The mechanism for determining the presence of a connected robot to the docking station occurs by measuring the resistance on the contact pads, and the power supply is switched on using a relay controlled by a mechanical switch.

The housing of the docking station is manufactured using laser cutting technology, then the parts are connected to the finished housing of the device. The front panel of the docking station has adjustable mounting holes for adjusting the plate in height relative to the floor to more accurately align with the spring-loaded contacts of the robot.

To determine the docking station by the robot, a QR or ArUco code with the station identification number is placed on the docking station, computer vision algorithms are used on the robot to search and read data from the code [6], [7], [8]. The spatial position of the station relative to the robot is calculated to determine the optimal trajectory of the robot's arrival at the docking station [10], [11].

6. Conclusion

In the AMUR-307 robot, weaknesses in the power system were identified, namely the lack of battery interfaces and insufficient protection mechanisms.

As a result of the research and development of the power supply system and its modules, several tasks were solved: managing the battery charging process, obtaining battery status information, and adding multi-level battery protection for a variety of parameters. This system is based on the SBS v1.1 specification for easy connection to Linux OS based on standard drivers.

The battery monitoring module reads all important parameters from the battery and transmits them directly to the charge controller, which reduces the computational load on the processor.

The charge controller module has 2 independent control circuits and each independently charges its battery, which in turn increases the reliability of the system as a whole, since if any component fails, the robot will continue to work on one battery.

For the automatic charging process, a docking station was designed and manufactured, which has an optical marker to identify the docking station and calculate its position to calculate the optimal arrival trajectory.

The developed system provides a unified modular assembly, which has also been applied for use on an underwater walking vehicle.

In the future, it is planned to develop software for the current sensors of the robot's motor drivers and analyze the force of each motor based on the data to obtain additional space parameters and surface characteristics for locomotion.

7. Acknowledgments

The study was partially funded by the grant from the Russian Science Foundation № 23-29-00720 and KIAM support.

8. References

- [1] Pryanichnikov, V[alentin]; Ksenzenko, A[lexander] & Plotnikov, A[leksey] (2022). Development of the Intelligent Robotic Systems, Proceedings of the 33rd DAAAM International Symposium, pp.0029-0033, B. Katalinic (Ed.), Published by DAAAM International, ISBN 978-3-902734-36-5, ISSN 1726-9679, Vienna, Austria DOI: 10.2507/33rd.daaam.proceedings.005.
- [2] Ricco, Mattia & Meng, Jinhao & Gherman, Tudor & Grandi, Gabriele & Teodorescu, Remus. (2019). Smart Battery Pack for Electric Vehicles Based on Active Balancing with Wireless Communication Feedback. *Energies*. 12. 3862. 10.3390/en12203862.
- [3] Petreus, Dorin & Patarau, Toma & Szilagyi, Eiko & Cirstea, Marcian. (2023). Electrical Vehicle Battery Charger Based on Smart Microgrid. *Energies*. 16. 3853. 10.3390/en16093853.
- [4] Wen, Y., Wolski, R., Krintz, C. (2005). Online Prediction of Battery Lifetime for Embedded and Mobile Devices. In: Falsafi, B., VijayKumar, T.N. (eds) *Power-Aware Computer Systems. PACS 2003. Lecture Notes in Computer Science*, vol 3164. Springer, Berlin, Heidelberg. https://doi.org/10.1007/978-3-540-28641-7_5
- [5] Davydov D.V., Eprikov S.R., Kirsanov K.B., Pryanichnikov V.E. (2017). Service Robots Integrating Software and Remote Reprogramming, Proceedings of the 28th DAAAM International Symposium, pp.1234-1240, B. Katalinic (Ed.), Published by DAAAM International, ISBN 978-3-902734-11-2, ISSN 1726-9679, Vienna, Austria DOI: 10.2507/28th.daaam.proceedings.172.
- [6] Pryanichnikov V. E. (2023) Development of remote sensing and control systems using image convolutions / XV Scientific and Practical Conference "Recording and reproduction of volumetric images in cinematography, science, education, media and other fields", Moscow, 3–5 April 2023.: Materials and documents // edited by O. N. Raev. — Moscow: IPP «KUNA», 2023. — 34 p. — S.87-101, ISBN 978-5-98547-144-1.
- [7] Volden, Ø., Stahl, A. & Fossen, T.I. (2022). Vision-based positioning system for auto-docking of unmanned surface vehicles (USVs). *Int J Intell Robot Appl* 6, 86–103. <https://doi.org/10.1007/s41315-021-00193-0>
- [8] Garrido-Jurado S. (2014). Automatic generation and detection of highly reliable fiducial markers under occlusion//*Pattern Recognition*. №6 (47). C. 2280 – 2292
- [9] R.B. Tarasov, O.I. Davydov, V.E. Pryanichnikov (2021). Software-control shell for service robots with parallel computing // *Robotics and technical cybernetics*. – T. 9. – № 2. – S. 99-105. – DOI 10.31776/RTCJ.9203. – EDN EUOQJP.
- [10] Nuchter A., Hertzberg J. (2008). Towards Semantic Maps for Mobile Robots. // *Robotics and Autonomous Systems*, vol. 56, no. 11, Nov. 2008, pp. 915–926.
- [11] Huang W. H., Beevers K. R. (2004). Topological Mapping with Sensing-limited Robots. // *In Proc. of the 6th International Workshop on the Algorithmic Foundations of Robotics (WAFR)*, pp. 367-382.
- [12] Pryanichnikov V.E., Chernyshev V.V., Arykancev V.V., Ayskin A.A, Ksenzenko A.YA., Petrakov M.S., Travushkin A.S., Eprikov S.R. (2019). Supervisory control of a walking underwater base with autonomous robotic satellites. *Intelligent adaptive robots // Information-measuring and control systems*. T. 16. № 1–2. S. 49–56. ISSN 2070-0814.
- [13] Chernyshev V. V., Pryanichnikov V. E., Arykantsev V. V. (2020). Algorithms of Self-control of the Underwater Walking Device According to Information on a Collision of Feet with an Unorganized Support Surface. In: Yuschenko A. (Eds) *Modern Problems of Robotics. MPoR2020. Communications in Computer and Information Science*, vol 1426. Springer, Cham. DOI https://doi.org/10.1007/978-3-030-88458-1_14, Print ISBN978-3-030-88457-4 Online ISBN978-3-030-88458-1.