

# THEORETICAL STUDY ON POWER PERFORMANCE OF AGRICULTURAL GANTRY SYSTEMS

Volodymyr Bulgakov, Volodymyr Kuvachov & Jüri Olt

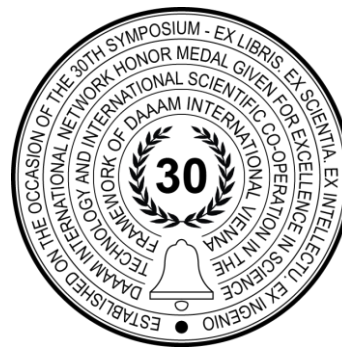

**This Publication has to be referred as:** Bulgakov, V[olodymyr]; Kuvachov, V[olodymyr] & Olt, J[ueri] (2019). Theoretical Study on Power Performance of Agricultural Gantry Systems, Proceedings of the 30th DAAAM International Symposium, pp.0167-0175, B. Katalinic (Ed.), Published by DAAAM International, ISBN 978-3-902734-22-8, ISSN 1726-9679, Vienna, Austria  
DOI: 10.2507/30th.daaam.proceedings.022

## Abstract

In terms of the future development of the mechanization and automation of the agricultural production, the transition from the narrow-gauge towing tractor to the wide-span (gantry) traction and power unit, also called the agricultural gantry system, seems to be a promising trend. For the purpose of combining implements with the agricultural gantry system with the use of a manifold power take-off system, it is necessary to undertake theoretical research into such power units with regard to their suitability for their functional purpose. The aim of the investigations was to analyze the laws governing the effect that the parameters and operation conditions of agricultural gantry systems have on their power balances and at the same time to outline the principal trends for the development of the theory of such machines with that aim in view. As a result of the investigations, it has been established that the power intensity rate of such agricultural gantry systems travelling at working speeds within a range of  $10 \text{ km}\cdot\text{h}^{-1}$  is equal to  $23.5 \text{ kW}\cdot\text{t}^{-1}$ . Also, the agricultural gantry system is capable of producing a traction force of  $6.37 \text{ kN}\cdot\text{t}^{-1}$  of its operating mass provided that a sufficient grip of its undercarriage on the surface of the permanent process track is ensured.

**Keywords:** wide span power unit; design and development; theory; traction force; power intensity.

## 1. Introduction

The implementation of soil protecting farming systems and power saving technologies belongs to the priority development trends in the mechanisation, motorisation and automation of the agricultural production. The mentioned trends can be pursued by developing conceptually new ways of performing the agricultural process operations on the basis of the principles of the permanent track and wide span farming systems, the automation and robotisation of agricultural processes etc. [1] and [2]. In this context, the transition from narrow-gauge towing tractors to wide-span or gantry traction and power units, so-called agricultural gantry systems, is seen as a promising trend [3] and [4]. The last option is not only a towing vehicle, but also the source of power for the combined agricultural implements travelling on the tracks of the permanent process gauge or on the service tracks specially engineered for the system [5].

The application of the agricultural gantry system as a single power and process module in permanent-track or wide-span farming systems provides for solving the problem of the efficient utilisation of the power output by its power unit (or power units) and the reduction of the soil compaction by its running gear [6].

Selecting the power rating for the power unit of such a wide-gauge gantry vehicle is one of the most complicated and critical problems at the initial stages of its development [7], [8], [9] and [10]. The primary requirement to and criterion of the correct choice of the power unit is the compliance of its effective power output and parameters with the conditions of the work process performed by the operated agricultural machinery [11], [12], [13], [14] and [15].

It is also worth mentioning that electric drives are more appropriate for the use in automated vehicles than power units with internal-combustion engines, since they are easier incorporated into automation systems. Apart from the mentioned advantage in connection with the automation trends, the use of electric drives allows reducing the overall consumption of oil products. The efficiency of their operation is ensured, when operating in fields equipped with the power grid for supplying power to gantry machines.

Nevertheless, the implementation of electric drives in vehicles faces the general problem of transmitting the power to the mobile machinery. We believe that the most promising option for the wide span farming is the hybrid drive in the agricultural gantry system, which includes a traction motor powered by batteries, a charging unit for recharging the batteries as well as an additional internal-combustion engine with a generator for the off-line operation. In view of the above, it is of current concern, with regard to the powering of the current generation of agricultural gantry systems, to develop a number of theoretical problems based on the fundamental provisions of the theory of tractor.

It is known from the classical theory of tractor that the power output of the engine in a conventional power unit is utilised mostly in the form of traction [16]. But, in the course of the continuing development of the designs of tractors and agricultural machinery as well as the agricultural crop production technologies etc., the practical situation has set a task for the science to substantiate the traction and power concept for the systems, in which the effective engine output cannot be fully utilised in the form of traction. This issue is elaborated in papers [17], [18], [19], which substantiate the practicality of using in the agricultural production not just towing tractors, but lighter and more power intensive tractors under the traction and power concept. Such an approach offers a possibility of abandoning the strict parametric dependence between the engine output and the weight of the towing tractor, when designing it, which will result in the considerable reduction of the material intensity of the machine.

Essentially, the gantry tractor of the traction and power concept is a brand new machine of the future. In the process of transition from the tractor to the agricultural gantry system combined with agricultural implements that have active tools and further to the agricultural gantry with a manifold power take-off system, it is necessary to carry out theoretical research into the power units under consideration with regard to their suitability for the functional purpose.

The aim of the presented investigation is to analyse the laws governing the effect that the parameters of agricultural gantry systems and their operation conditions have on their power balances and at the same time to determine the principal development trends for the theory of such machines along that line.

## 2. Materials and Methods

The theoretical investigations and the synthesis of the structural layouts and parameters of agricultural gantry systems were carried out by means of the PC-assisted modelling of the conditions of their functioning. The research methods were based on the fundamentals of the theory of tractor and the theoretical mechanics and involved the use of the Mathcad software package.

The agricultural gantry system under consideration (Fig. 1) comprises heavy-duty power unit 1, wide-gauge self-propelled tool carrier 2 with steerable wheels 3 and 4 mounted on the wheel bogies 5 and 6 on its left and right sides, transmission system 7 (or motorised wheels) for driving them, frame 8 for the attachment of agricultural tools 9, mechanical power take-off system 10 for the actuation of the tools, lifting mechanisms 11 with an electromechanical or hydraulic power drive.

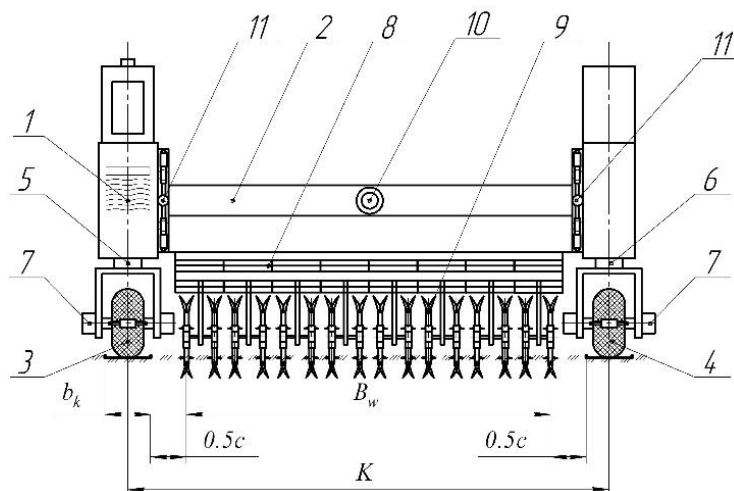

Fig. 1. Schematic model of agricultural gantry system travelling on treads of permanent process track

The agricultural gantry system travels on the treads of the permanent process track or the specially engineered service tracks with a width of  $b_k$  (Fig.1). The gauge of the track of the agricultural gantry system is equal to  $K$ . Taking into account the protection zone width of  $c$ , the working width of the span is equal to  $B_w$ .

The wheel gauges  $K$  of agricultural gantry systems can vary, depending on the design. For the globally recognised models of wide span agricultural machines and gantry tractors the wheel gauge varies within 3 to 10 m. In view of the prospects for the use of wide-gauge agricultural gantry systems, this value can be increased to 30 and even 100 m.

In essence, in order to determine the nominal effective output of the power unit of the agricultural gantry system it is necessary to sum up the usefully expended power and the power consumption resulting from the expenditure of energy for the friction in the transmission, the slipping of the running gear and overcoming the rolling resistance (Fig. 2).

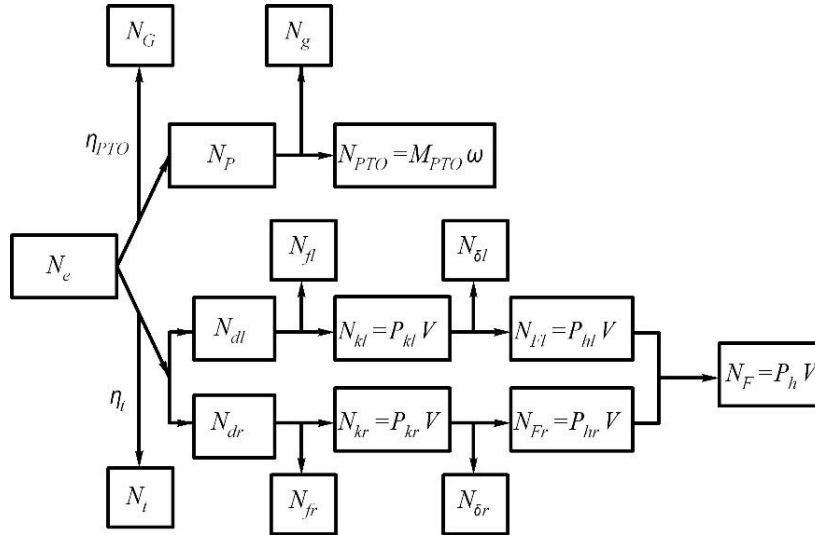

Fig. 2. Block diagram of power flows in agricultural gantry system with additional power take-off

In accordance with the block diagram above (Fig. 2), the effective output  $N_e$  of the power unit in the agricultural gantry system is spent for the usefully expended work – transfer of power via the transmission gear for driving the undercarriage of its left and right sides and, via the power take-off system, for driving the active tools of the agricultural implements or driving the process equipment. During the transfer of the power flow via the transmission gear, the losses  $N_i$  that can be evaluated with the use of the efficiency factor  $\eta_t$  arise in it. Part of the power consumed by the driving wheels of the left and right sides ( $N_{dl}$ ,  $N_{dr}$ ) of the agricultural gantry system is spent for overcoming the resistance to their rolling ( $N_{fl}$ ,  $N_{fr}$ ). Thereafter, the resulting power at the tyres of the driving wheels on the left and right sides ( $N_{kl}$ ,  $N_{kr}$ ) is spent for slipping ( $N_{\delta l}$ ,  $N_{\delta r}$ ) as well as the useful traction power  $N_F$  determined by the tractive effort at drawbar  $P_h$  and the agricultural gantry system travel speed  $V$ .

When the power  $N_P$  is transferred via the power take-off system to the active tools of the agricultural implements, which receive  $N_{PTO}$  determined by the torque  $M_{PTO}$  and angular velocity  $\omega$  of the output drive shaft, the losses of power in the reduction gearbox  $N_G$  and in the drive  $N_g$  evaluated with the use of the efficiency factor  $\eta_{PTO}$  are to be taken into account.

### 3. Results and Discussion

On the basis of the block diagram of power flows in the agricultural gantry system (Fig. 2), it is possible to generate the following equation of power balance that allows evaluating the power inputs during its functioning. According to the equation, the power output of the power unit (or power units) is distributed between the two sides, while in certain cases it can be additionally spent for power take-off (via the power take-off system):

$$N_e = \frac{N_{dl} + N_{dr}}{\eta_t} + \frac{N_{PTO}}{\eta_{PTO}} \cdot \tag{1}$$

In order to determine the power input for the functioning of the agricultural gantry system, the diagram of forces acting on it (Fig. 3) will be analysed. In this analysis, it is assumed that the drawbar mass of the agricultural gantry system  $M$  is distributed between its left and right sides as the masses  $M_1$  and  $M_2$  ( $M = M_1 + M_2$ ) located at points  $L$  and  $R$ , respectively.

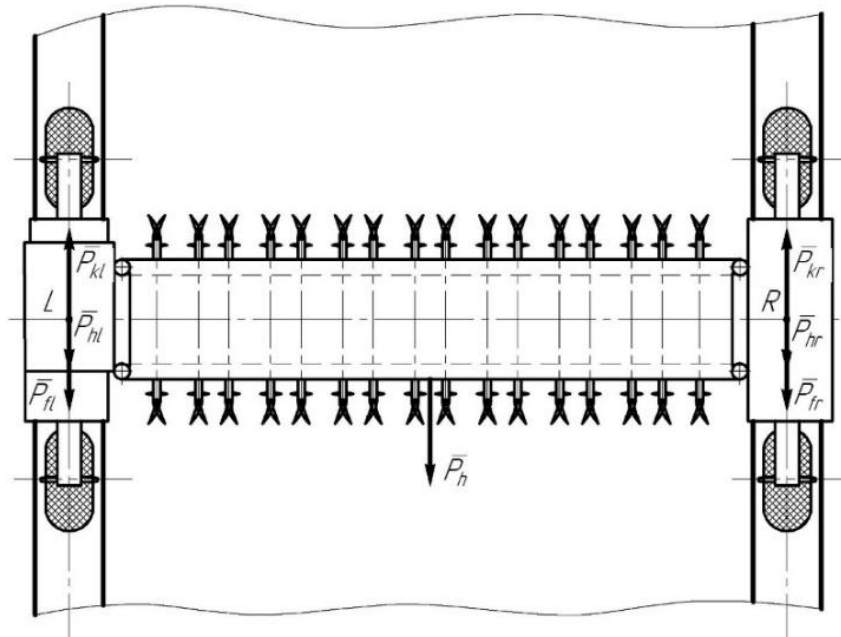

Fig. 3. Diagram of forces acting on agricultural gantry system travelling on treads of permanent process track

It can be concluded from Fig. 3 that the agricultural gantry system is under the action of the tangential  $P_{kl}$ ,  $P_{kr}$  and drawbar  $P_{hl}$ ,  $P_{hr}$  traction forces generated by the running gear on the left and right sides and the rolling resistance forces  $P_{fl}$  and  $P_{fr}$ .

When the agricultural gantry system travels in a steady state at a velocity of  $V$ , the required power for the left and right sides can be determined from the following equations:

$$\begin{aligned} N_{dl} &= P_{fl}V_l + P_{kl}V_l\delta_l + P_{hl}V_l, \\ N_{dr} &= P_{fr}V_r + P_{kr}V_r\delta_r + P_{hr}V_r, \end{aligned} \quad (2)$$

where  $V_l$ ,  $V_r$ ,  $\delta_l$ ,  $\delta_r$  – theoretical velocities of translation and slipping of the running gear on the left and right sides of the agricultural gantry system.

Taking into account the approximate equality of the drawbar mass and the operating mass of the agricultural gantry system and following the theory of tractor, the tangential traction forces, rolling resistance forces and theoretical velocities of translation will be determined from the following equations:

$$\begin{aligned} P_{kl} &= P_{fl} + P_{hl}; & P_{fl} &= fM_l g; \\ P_{kr} &= P_{fr} + P_{hr}; & P_{fr} &= fM_r g; \\ V_l &= \frac{V}{1 - \delta_l}; & V_r &= \frac{V}{1 - \delta_r}, \end{aligned} \quad (3)$$

where  $f$  – coefficient of rolling resistance,  
 $g$  – free fall acceleration.

Basing on the assumption of the sufficient grip of the agricultural gantry system's running gear on the soil, the tractive effort that can be generated by it will be determined from the following equation:

$$P_h = P_{hl} + P_{hr} = Mg(\lambda\phi - f), \quad (4)$$

where  $\lambda$  – load factor of driving wheels,

$\phi$  – coefficient of traction of the agricultural gantry system's running gear on the background of the process track.

After substituting the equations (2-4) into (1), the power balance equation will appear as follows:

$$\begin{aligned} N_a &= \frac{fgV}{\eta_i} \left[ \frac{M_l}{1 - \delta_l} + \frac{M_r}{1 - \delta_r} \right] + \frac{\lambda\phi gV}{\eta_i} \left[ \frac{M_l\delta_l}{1 - \delta_l} + \frac{M_r\delta_r}{1 - \delta_r} \right] + \\ &+ \frac{gV(\lambda\phi - f)}{\eta_i} \left[ \frac{M_l}{1 - \delta_l} + \frac{M_r}{1 - \delta_r} \right] + \frac{N_{PTO}}{\eta_{PTO}}. \end{aligned} \quad (5)$$

Thus, the obtained power balance equation (5) takes into account not only the traction load of the agricultural gantry system, the additional power take-off and the conditions of the system functioning, but also the drawbar weight applied to its left and right sides.

Considering the fact that the operational weight of the agricultural gantry system is equal to the sum of its drawbar weights applied to the left and right sides, the obtained equation (5) provides for calculating the power intensity of the system:

$$E = \frac{N_e}{M} \tag{6}$$

where  $E$  – power intensity of the agricultural gantry system ( $\text{kW} \cdot \text{t}^{-1}$ ).

In view of the conditions of translation of the agricultural gantry system on the hard background in the treads of the process track, the following values of the parameters are assumed for the analysis:  $f = 0.05$ ;  $\varphi = 0.7$ ;  $\lambda = 1$ ;  $\eta_i = 0.941$ ;  $g = 9.81 \text{ m} \cdot \text{s}^{-2}$ . Also, for the purposes of the analysis it is assumed that the rate of slipping of the running gear on the left and right sides of the agricultural gantry system does not exceed the maximum acceptable value  $\delta_l = \delta_r = 14\%$ .

The power intensity rate  $E$  can be represented by the function of the operating translation rate  $E = f(V)$  (Fig. 4).

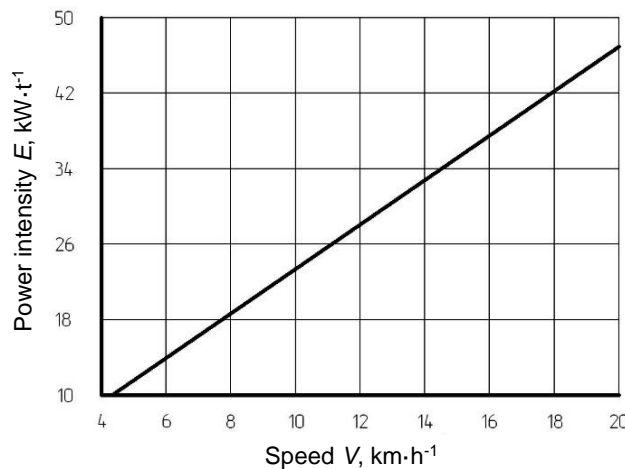

Fig. 4. Power intensity of agricultural gantry system without additional power take-off as function of translation rate

In our predictive estimate, the practical implementation of agricultural gantry systems will take place in stages. At the first stage, in view of the power limitations, the operating speeds will not exceed  $10 \text{ km} \cdot \text{h}^{-1}$ , which is typical for the majority of today's agricultural machines. In this case, the power intensity without regard to the additional power take-off will be at a rate of  $23.5 \text{ kW} \cdot \text{t}^{-1}$  (Fig. 4).

In the near future, it is conceivable that the conventional tools of agricultural implements will be replaced by brand new ones, capable of operating at higher rates, which will necessitate the proportional increase of the power intensity of the agricultural gantry systems. For that purpose, the dependence between their power intensity and the translation rate is approximated by the following linear functional equation:

$$E = 2.3562 V + \frac{N'_{PTO}}{M} \tag{7}$$

where  $N'_{PTO} = N_{PTO} \cdot (\eta_{PTO})^{-1}$ .

The final value of the power intensity according to (7) depends on the amount of the additional power take-off  $N'_{PTO}$  the value of which depends on the functional purpose of the particular agricultural gantry system.

According to the shown dependence (Fig. 5) between the power intensity and the specific value of the additional power take-off per tonne of operating mass of the agricultural gantry system, the increase of the power take-off (PTO) by  $1 \text{ kW} \cdot \text{t}^{-1}$  is followed by the increase of the power intensity in direct proportion.

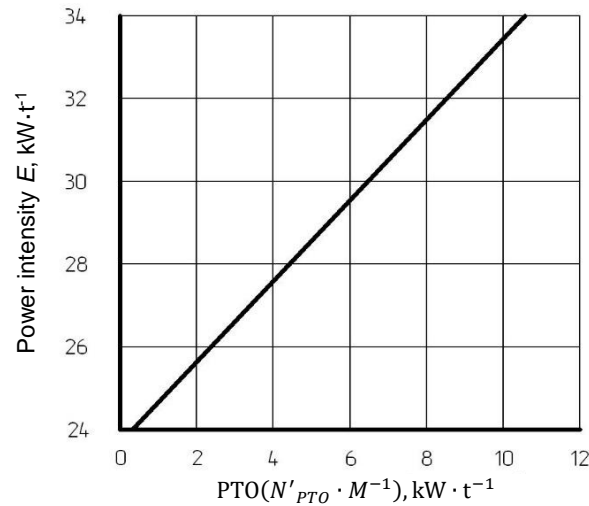

Fig. 5. Dependence between power intensity of agricultural gantry system and additional power take-off (PTO) per tonne of operating mass at operating speeds not exceeding 10 km·h<sup>-1</sup>

The rated tractive effort generated in this context by the agricultural gantry system as a function of the operating mass is presented in Fig. 6.

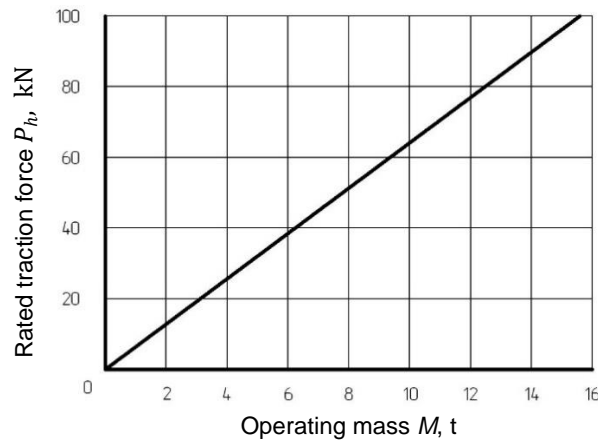

Fig. 6. Rated traction force generated by agricultural gantry system subject to sufficient grip of its undercarriage on soil and slipping rate within acceptable range

The scientific and practical importance of the functional relation presented in Fig. 6 is in that it shows the capability of the agricultural gantry system to generate a tractive effort of 6.37 kN per tonne of its operating mass.

The traction force  $P_h$  generated in the agricultural gantry system is stipulated by the specific drawbar resistance of the particular agricultural implement and its working span width:

$$P_h = k_0 \cdot \left( 1 + \frac{c_v}{100} (V - V_0) \right) \cdot B_w, \quad (8)$$

where  $k_0$  – specific drawbar resistance of the agricultural implement at a travel speed of  $V_0$  (kN·m<sup>-1</sup>),

$V_0$  – rated travel speed equal to 5 km·h<sup>-1</sup>,

$c_v$  – rate of the specific drawbar resistance increase due to the increase of the travel speed (%),

$B_w$  – working span width of the agricultural gantry system, which, according to Fig. 1, is equal to:

$$B_w = K - b_k - c \quad (9)$$

It follows from the equation (8) that increasing the rate of travel of highly power intensive agricultural gantry systems does not resolve the problem of their effective utilisation. That is due to the fact that the specific drawbar resistances of the tools of the agricultural implements grow together with the increase of the translation rate, which entails the growth of the power input for the performance of the work process.

The results of the calculations of the mass and the effective output of the power unit of the agricultural gantry system required for the performance of particular process operations are presented in Table 1.

---

Process operation	Agricultural implement	Specific drawbar resistance $k_0$ (kN·m <sup>-1</sup> )	Agronomic velocity $V$ (km·h <sup>-1</sup> )	Mass (t) and power (kW) of agricultural gantry system depending on its gauge width $K$							
				$K = 3m$		$K = 10m$		$K = 30m$		$K = 100m$	
				$M$	$N_e$	$M$	$N_e$	$M$	$N_e$	$M$	$N_e$
Harrowing	Toothed harrows:										
	heavy duty	0.4-0.7	7-12	0.41	12.6	1.36	41.7	4.08	125	13.6	417
	normal duty	0.3-0.6		0.35	10.7	1.17	35.9	3.5	107	11.6	357
	seed harrows	0.25-0.45		0.26	8	0.87	26.7	2.62	80.4	8.74	268.
	chain and sweeper harrows	0.45-0.65		0.38	11.7	1.26	38.7	3.79	116	12.6	387
	spring-tooth and chisel harrows	1.0-1.8		1.05	32.2	3.5	107	10.4	321	34.9	1072
	soil spikers	0.45-0.65		0.38	11.7	1.26	38.7	3.79	116	12.6	387
	Disk harrows:										
	stubble field disking	1.6-2.2	5-10	1.04	26.6	3.48	89	10.4	267	34.8	890
	broken ground disking	3.0-6.0		2.85	72.9	9.5	242	28.4	728	94.9	2,428
grassland disking	4.0-6.0	2.85		72.9	9.5	242	28.4	728	94.9	2,428	
Full cultivation	Cultivators:										
	general-tillage cultivator – tilling depth of 6-8 cm	1.2-2.6	9-15	1.68	64.4	5.61	215	16.8	645	56.1	2,152
	general-tillage cultivator – tilling depth of 10-12 cm	1.6-3.0		1.94	74.4	6.47	248	19.4	744	64.7	2,483
rod weeder – tilling depth of 10-12 cm	1.6-2.6	5-7	1.23	22	4.12	73.7	12.3	221	41.1	736	
Interspace cultivation			1.2-1.8	7...10	0.97	24.8	3.24	82.9	9.71	248	32.3
Subsoil ploughing	Chisel cultivators	8.0-13.0	7-10	7.01	179	23.3	597	70.1	1793	233	5,979
Subsurface ploughing	Blade cultivators	4.0-6.0	8-12	3.5	107	11.6	357	34.9	1072	116	3,576
Stubble ploughing	Stubble ploughs:										
	disk tiller – tilling depth of 8-10 cm	1.2-2.6	7-12	1.28	39.3	4.26	130	12.7	392	42.6	1,308
	shallow plough – ploughing depth of 10-14 cm	2.5-6.0	8-10	2.85	72.9	9.5	242	28.4	728	94.9	2,428
	shallow plough – ploughing depth of 14-18 cm	6.0-10.0	8-10	4.75	121	15.8	404	47.4	1214	158	4,047
Drill seeding of grain crops	Drilling machines:										
	disk drill with row spacing of 15 cm	1.1-1.6	10-15	0.97	37.2	3.22	123	9.67	370	32.2	1,236
	close-row drill	1.5-2.5		1.51	57.9	5.04	193	15.1	579	50.3	1,931
	disk drill and packer	1.2-1.8		1.09	41.8	3.63	139	10.8	417	36.2	1,390
tiller drill	1.2-2.8	1.69		64.8	5.64	216	16.9	649	56.4	2,163	
Seeding of beets			0.6-1.0	6...7.5	0.47	9.0	1.58	30.3	4.75	91.1	15.8
Seeding of corn, sunflower			1.0-1.4	6...7.5	0.66	12.7	2.22	42.6	6.65	127	22.1
Planting of vegetables, potatoes			2.5-3.5	5...9	1.75	40.3	5.84	134	17.5	403	58.4
Rolling	Water-filled rollers	0.55-1.2	4-8	0.55	11.3	1.83	37.4	5.49	112	18.3	374
	Star-wheeled rollers	0.6-1.0	6-12	0.49	15	1.64	50.3	4.92	151	16.4	503
	Sprocket packers	0.6-1.0	4-9	0.47	10.8	1.55	35.7	4.66	107	15.5	357

Table 1. Results of calculations of mass and effective power unit output of agricultural gantry system required for performance of particular process operations

The results obtained in the analysis of the mass and power of agricultural gantry systems, when they perform different process operations, provide valuable scientific material that can be used in the design and development of the similar mechanical equipment for the crop growing industry.

#### **4. Conclusion**

1. Agricultural gantry systems are lately gaining interest in the world, which allows implementing a controlled traffic farming technology. The problem is to ensure stable motion of the gantry power unit. The design of its linkage has to provide for its independent turning on the horizontal plane. This study investigates into the details of hitching the gantry power systems with agricultural machines and implements.

2. The obtained power balance equation for an agricultural gantry system travelling on the treads of the permanent process track takes into account not only the traction load and the additional power take-off, but also the specific features of its structural layout, which provides for estimating the level of power intensity of the machine already at the stage of its designing.

3. Basing on the assumption that the agricultural gantry system travels on the hard and levelled up background of the treads of the permanent process track, the desired value of its power intensity at its travel speeds within the range of  $10 \text{ km}\cdot\text{h}^{-1}$  falls on a rate of  $23.5 \text{ kW}\cdot\text{t}^{-1}$ . At the same time, the agricultural gantry system is capable of generating a tractive effort of  $6.37 \text{ kN}$  per tonne of its operating mass subject to the sufficient grip of its running gear on the surface of the permanent process track.

4. Increasing the rate of travel of highly power intensive agricultural gantry systems does not resolve the problem of their effective utilisation. That is due to the fact that the specific drawbar resistances of the tools of the agricultural implements grow together with the increase of the translation rate, which entails the growth of the power input for the performance of the work process.

5. The results obtained in the analysis of the mass and power of agricultural gantry systems, when they perform different process operations, provide valuable scientific material that can be used in the design and development of the similar mechanical equipment for the crop growing industry.

6. Future research plans are aimed at: a) optimisation of the vertical load of the wheels of the gantry traction and power unit; b) improvement in the pulling characteristics of the agricultural power unit, and c) decrease in the influence of soil treading.

#### **5. References**

- [1] Chamen T. (2015). Controlled traffic farming – from world wide research to adoption in Europe and its future prospects. *Acta Technologica Agriculturae Nitra*, Vol 3, pp. 64-73.
- [2] Onal I. (2012). Controlled Traffic farming and Wide Span Tractors. *Journal of Agricultural Machinery Science*, Vol. 8, No. 4, pp. 353-364.
- [3] Pedersen, H.H. (2011). Harvest Capacity Model for a Wide Span Onion Bunker Harvester. *Automation and System Technology in Plant Production, CIGR section V & NJF section VII conference*, pp. 27-36.
- [4] Pedersen, H.H., Oudshoorn, F.W., McPhee, J.E., Chamne, W.C.T. (2016) Wide span – Re-mechanising vegetable production. *Acta Horticulturae*, Vol 1130, pp. 551-557., ISSN: 05677572, DOI: 10.17660/ActaHortic.2016.1130.83.
- [5] Bulgakov, V.; Adamchuk, V.; Kuvachov, V.; Arak, M. & Olt, J. (2017). Study into movement of wide span tractors (vehicles) used in controlled traffic farming, *Proceedings of the 28th DAAAM International Symposium*, pp. 0199-0208, B. Katalinic (Ed.), Published by DAAAM International, ISBN 978-3-902734-11-2, ISSN 1726-9679, Vienna, Austria, DOI: 10.2507/28th.daaam.proceedings.027.
- [6] Bulgakov, V.; Melnik, V.; Kuvachov, V. & Olt, J. (2018). Theoretical study on linkage unit of wide span tractor, *Proceedings of the 29th DAAAM International Symposium*, pp. 0180-0189, B. Katalinic (Ed.), Published by DAAAM International, ISBN 978-3-902734-20-4, ISSN 1726-9679, Vienna, Austria, DOI: 10.2507/29th.daaam.proceedings.026.
- [7] Bulgakov V., Nadykto V., Velichko I., Ivanovs S. (2016). Investigation of draft coefficient of efficiency of wheeled tractor. *Engineering for rural development*, Jelgava, 25-27.05.2016.
- [8] Simikič M., Dedovič N., Savin L., Tomič M. & Ponjičan O. (2014). Power delivery efficiency of a wheeled tractor at oblique drawbar force. *Soil and Tillage Research*, Vol 141, pp. 32–43.
- [9] Turker U., Ergul I. & Eroglu M.C. (2012). Energy efficiency classification of agricultural tractors in Turkey based on OECD tests. *Energy Education Science and Technology. Part A: Energy Science and Research*, Vol 28, No. 2, pp. 917–924.
- [10] Chang Seop Shin , Kyeong Uk Kim, Kwan Woo Kim. (2012). Energy Efficiency Classification of Agricultural Tractors in Korea. *J. of Biosystems Eng*, Vol 37, No. 4, pp. 215-224.
- [11] Pochi D., Fanigliulo R., Pagano M., Grilli R., Fedrizzi M., Fornaciari L. (2013). Dynamic-energetic balance of agricultural tractors: active systems for the measurement of the power requirements in static tests and under field conditions. *Journal of Agricultural Engineering*, Vol XLIV(S2): e 84.



- [12] Cutini M. & Bisaglia C. (2016). Development of a dynamometric vehicle to assess the drawbar performance of high-powered agricultural tractors. *Journal of Terramechanics*, Vol 65, pp. 73–84.
- [13] Gil-Sierra J., Ortiz-Cañavate J., Gil-Quiros V. & Casanova-Kindelan J. (2007). Energy efficiency in agricultural tractors: A methodology for their classification. *Applied Engineering in Agriculture*, Vol 23, No. 2, pp. 145–150.
- [14] Moitzi G., Wagentristl H., Refenner K., Weingartmann H., Piringer G., Boxberger J. & Gronauer A. (2014). Effects of working depth and wheel slip on fuel consumption of selected tillage implements. *Agricultural Engineering International: The CIGR e-journal*, Vol 16, No. 1, pp. 182–190.
- [15] Monteiro L.A., Albiero D., de Souza F.H., Melo R.P. & Cordeiro I.M. (2013). Tractor drawbar efficiency at different weight and power ratios. *Revista Ciencia Agronomica*, Vol 44, No. 1, pp. 70–75.
- [16] Adamchuk V., Bulgakov V., Nadykto V., Ihnatiev Y. and Olt J. (2016). Theoretical research into the power and energy performance of agricultural tractors. *Agronomy Research* Vol 14, No. 5, pp. 1511–1518, ISSN 1406-894X.
- [17] Nadykto V. (2014). Determining maximum slipping rate of wheeled running gear in context of limiting its pressure on soil. *Machinery and Technologies of Agro-Industry*, Vol 7, pp. 34–37.
- [18] Nadykto V., Arak M. & Olt J. (2015). Theoretical research into the frictional slipping of wheel-type propelling units taking into account the limitation of their impact on the soil. *Agronomy Research*, Vol 13, No. 1, pp. 148–157, ISSN 1406-894X.
- [19] Wong, J.Y. (2008). *Theory of ground vehicles*. John Wiley & Sons, ISBN 978-0-470-17038-0.